



Solido SMART XL

Adare Biocare Ltd

Tynedale House
Clonshire, Croagh,
Co Limerick
P: 061-395819

www.adarebiocare.com

Solido[®]
SMART



The Solido SMART XL brings unrivalled flexibility to the sewage treatment market.

A wastewater treatment plant, the Solido SMART XL is a modular sequencing batch reactor (SBR) system suitable for population equivalents (PE) of 25 - 125.

Ideal For:

- Pubs
- Restaurants
- Hotels
- Golf Clubs
- Nursing Homes
- Housing Estates

Using less power than traditional systems, the Solido SMART XL is a modular system enabling additional reactor tanks to be added should the business require them.



Setting the Standard for Excellence:

Unlike most compressors which are often subject to failure due to temperature fluctuations – the Solid SMART XL compressor is fed by a fresh air intake hose which is housed in a sealed, waterproof capsule.

A quiet plant with an integrated technology capsule, the Solid SMART XL is robust and can be installed in heavy grounds and areas with a high-water table.

Superior Technical Performance

The highly successful Solid SMART XL is designed and tested in accordance with EN12556-3. This plant will produce a final effluent quality better than 10:2 (BOD:SS:NH3) with a CE mark for 5:13:0.7 and conforms to the cleaning categories of Carbon and Nitrogen degradation.

Innovative Technology

Using batch processing the compressor only runs when it is needed. Which not only makes the system more economical but also prolongs the life of all component parts.

Holiday Mode

Absence periods can be programmed for up-to 120 days per year. During this period, the running time for aeration and pumping will be reduced by half.

Key Features:

- **In-built Alarm**
For peace of mind.
- **Discrete Design**
No large dome lids, making it ideal for gardens or driveways.
- **Drivable Covers**
Options available for up to 11.5 tonnes.
- **Increased Reliability**
Less temperature fluctuations as compressors are housed in a separate capsule.
- **Low power consumption**
50 kWh per PE per year (the equivalent of just €330 - €670 a year for the average development (50-100PE) @ 12 p/kWh).
- **Programmable**
Cycle times can be changed according to flow patterns.
- **Quick and simple installation**
No need for a concrete surround only one pre-finished pipe between the tank and house is required.

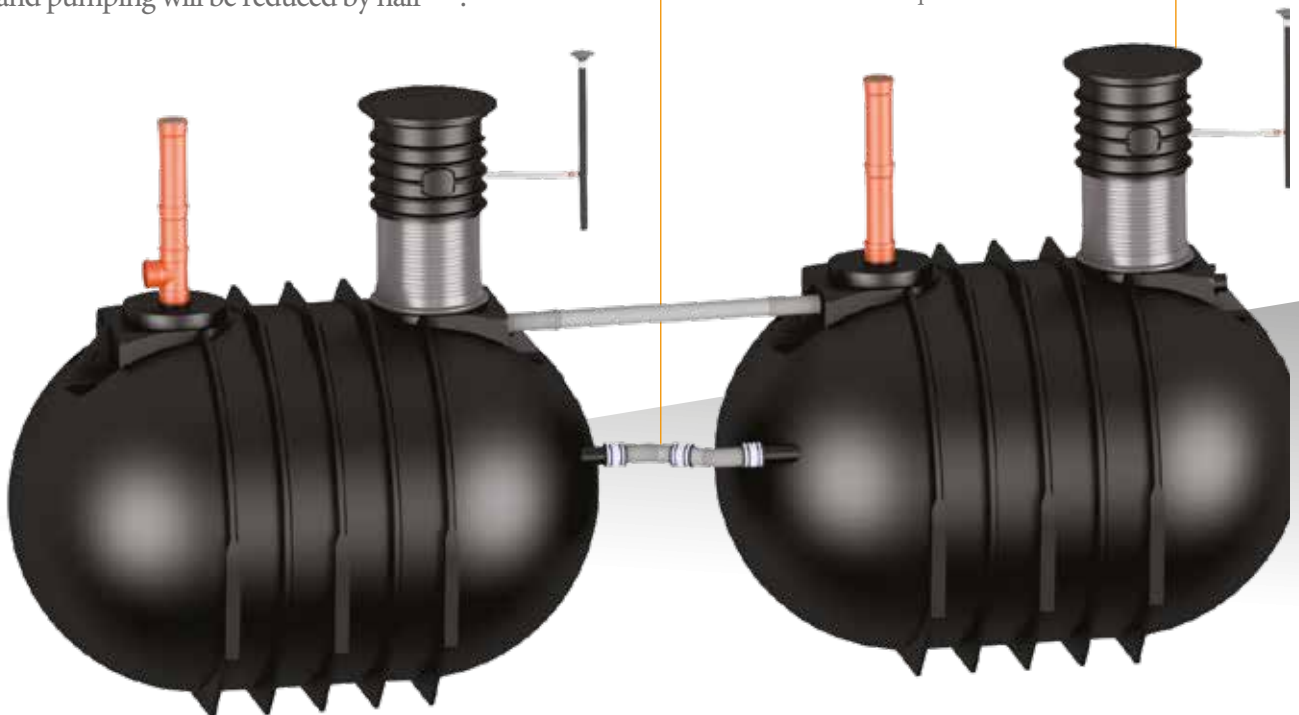

Why choose anything else, when the Solido SMART XL is:

- Designed for a lifetime .
- EN12566-3 certified
- **25-year** tank guarantee .
- **12 month** component guarantee (when commissioned by a PT AIE partner).



Technical Details

Data Sheet (standard scope of delivery with VS 60)

Type / Capacity	Order Number	Max Flow (m ³ /d)	Max Flow in 12h (m ³)	Max Load (kg of BOD ₅ /d)	Sludge Storage (m ³)	Length (cm)	Width (cm)	Height (inc. shaft - cm)	Weight (kg)
EBL-76x2 10-40 PE	KEBL 76X2	5.1	4.2	2.0	7.8	2 x 277	231	291 - 334	2 x 280
EBL-99X2 12-50 PE	KEBL 99X2	7.5	5.6	3.0	11	2 x 340	231	291 - 334	2 x 370
EBL-99X3 18-75 PE	KEBL 99X3	11.3	8.4	4.5	16.5	3 x 340	231	291 - 334	3 x 370
EBL-99X4 25-100 PE	KEBL 99X4	15.0	11.2	6.0	22	4 x 340	231	291 - 334	4 x 370
EBL-99X5 30-125 PE	KEBL 99X5	18.8	14	7.5	27.5	5 x 340	231	291 - 334	5 x 370

A member of:



Adare Biocare Ltd

Tynedale House
Clonshire, Croagh,
Co Limerick
P: 061-395819

www.adarebiocare.com

